

# CTS Series

2.5 LPM Free Flow

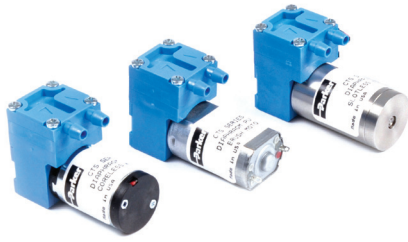

## Micro Diaphragm Pumps (air/gas)

Parker's CTS Micro Diaphragm Pump Model delivers up to 2.5 slpm of flow into a compact 20 mm wide package. Configurable with three different motors to meet your application's specific needs and life expectations

### Typical Applications:

- Gas Analyzers
- Patient Monitoring
- CO<sub>2</sub> Monitors
- Compression Therapy
- Negative Pressure Wound Therapy
- Surgical Instruments
- Medical Consumer Devices

### Features

- CTS Series Pumps set the highest benchmark for life-expectancy with our advanced proprietary diaphragm elastomer.
- CTS Series Pumps have a unique, compact, and lightweight design making it ideal for portable applications.
- Our 100% oil and grease-free pump and compressor design maintains the purity of your system and are commonly used in FDA-approved systems.
- CTS Series Pumps are uniquely balanced to minimize noise and vibration and to maximize life.
- RoHS compliant. 

## Product Specifications\*

### Physical Properties

<b>Operating Environment<sup>1</sup>:</b>
41 to 122°F (5 to 50°C)
<b>Storage Environment:</b>
-4 to 212°F (-20 to 100°C)
<b>Media:</b>
Air, Argon, Helium, Nitrogen, Oxygen, and other non-reacting gases
<b>Humidity:</b>
0 – 80% Relative Humidity
<b>Noise Level<sup>2</sup>:</b>
As low as 45 dB @ 12 in (30 cm)
<i>Muffler recommended for additional noise reduction (see accessories)</i>
<b>Pump Assembly Rated Life<sup>3</sup>:</b>
PMDC Iron Core Brush - 1,500 hrs
Coreless Brush - 3,000 hrs
Brushless Slotless - 10,000 hrs
<b>Weight:</b>
1.7 oz. (48 g) PMDC Iron Core Brush
1.6 oz. (45 g) Coreless Brush
2.2 oz. (62 g) Brushless Slotless

### Electrical

<b>Motor Type (DC):</b>
PMDC Iron Core Brush
Coreless Brush
Brushless Slotless
<b>Nominal Motor Voltages<sup>4</sup>:</b>
PMDC Iron Core Brush: 6, 9, 12, 24 VDC
Coreless Brush: 6, 9, 12, 24 VDC
Brushless Slotless: 6, 9, or 12 VDC
<i>Other voltages available upon request.</i>
<b>Max Power at Nominal Voltage:</b>
See Performance Specification Curves
<b>Electrical Termination:</b>
Iron Core Brush: Metal Terminals
Brush: 24 AWG Wire Leads, Length 20" (508 mm)
Brushless Slotless: 24 AWG Wire Leads, Length 20" (508 mm)
<b>Current Range<sup>5</sup>:</b>
240 - 880 mA

### Pneumatic

<b>Head Configuration:</b>
Single
<b>Maximum Unrestricted Flow:</b>
2.5 LPM (See Performance Specifications)
<b>Pressure Range:</b>
0 - 24 psig (0 - 1.65 bar)
<b>Vacuum Range:</b>
0 - 20 in Hg (0 - 508 mm Hg)
<b>Filtration:</b>
40 microns - recommended
<b>Efficiency at Free Flow<sup>6</sup>:</b>
PMDC Iron Core Brush: 1.7 LPM/Watt (PN: E107-12-090)
Coreless Brush: 2.8 LPM/Watt (PN: E165-11-060)
Brushless Slotless: 1.8 LPM/Watt (PN: E257-11)
<b>Wetted Materials</b>
<b>Diaphragm:</b>
EPDM, AEPDM, FKM
<b>Valves:</b>
EPDM, AEPDM, FKM
<b>Pump Head:</b>
PSU (Polysulfone)

\* See Appendix A for details.

## Performance Specifications

## CTS - PMDC Iron Core Brush

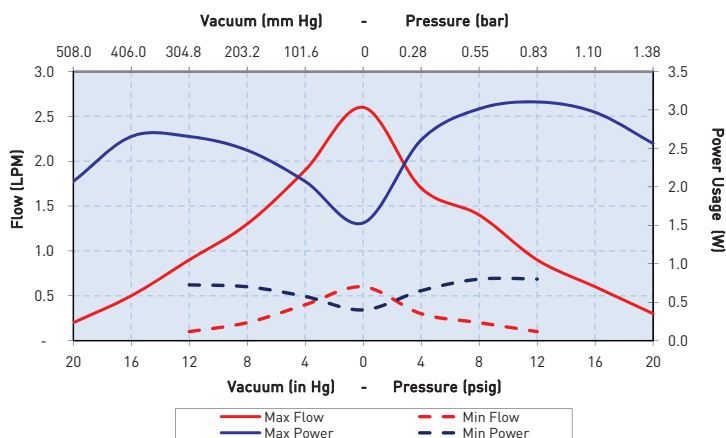

## CTS - Coreless Brush Motor

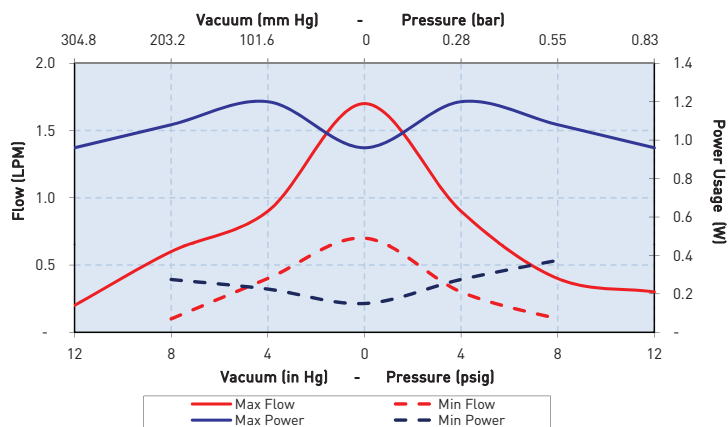

## CTS - Brushless Slotless Motor

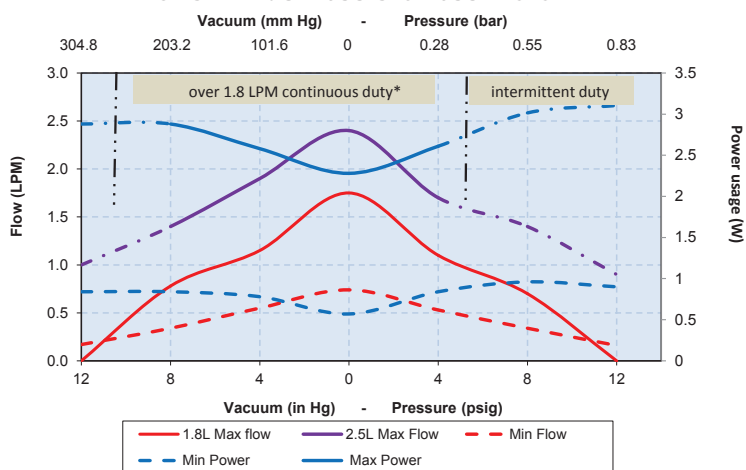

The above graphs represent an example of performance for the pump series handling air at 800 feet (244 m) above sea level at 75°F (24°C). Performance will vary depending on barometric pressure and media temperature. A variety of configurations can be accommodated to meet application requirements. Curves are representative of standard pump configurations. Pump configurations could be customized for higher or lower flows depending on specific customer requirements.

\* Continuous duty pressure/vacuum range for Brushless performance above 1.8LPM

Please contact Parker Precision Fluidics Applications Engineering for other considerations.

# CTS Series

## Micro Diaphragm Pumps (air/gas)

### Sizing and Selection

<b>CTS Series</b>	PMDC Iron Core Brush	Coreless Brush Motor	Brushless Slotless Motor
-------------------	----------------------	----------------------	--------------------------

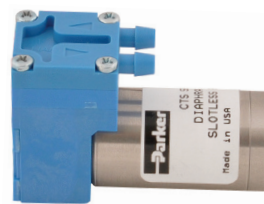
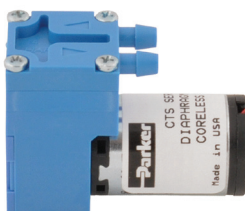
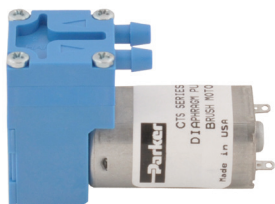

	PMDC Iron Core Brush	Coreless Brush Motor	Brushless Slotless Motor
<b>Efficiency<sup>1</sup></b>	Good	Best - Brush Motor Efficiency Up to 90% motor efficiency	Better Up to 75% motor efficiency
<b>Life<sup>2</sup></b>	Good - 1,500 hrs	Better - 3,000 hrs	Best - 10,000 hrs
<b>Cost</b>	Best	Better	Premium
<b>Noise</b>	Good	Better	Best

See Appendix A for details.

#### Mounting Guidelines:

- Mounting may be accomplished by using double-sided tape or wire zip ties secured to the motor housing or using a nylon cable tie with a length of at least 4" (100 mm).
- Hole in the center of the bottom of housing is for manufacturing only—not to be used for mounting.

#### Port Connections:

- Barbs are sized for 1/8" (3 mm) ID tubing, 70-80 durometer recommended.
- Flow direction is marked on the pump head with arrows.

### Mechanical Integration

#### Dimensions

PMDC Iron Core Brush

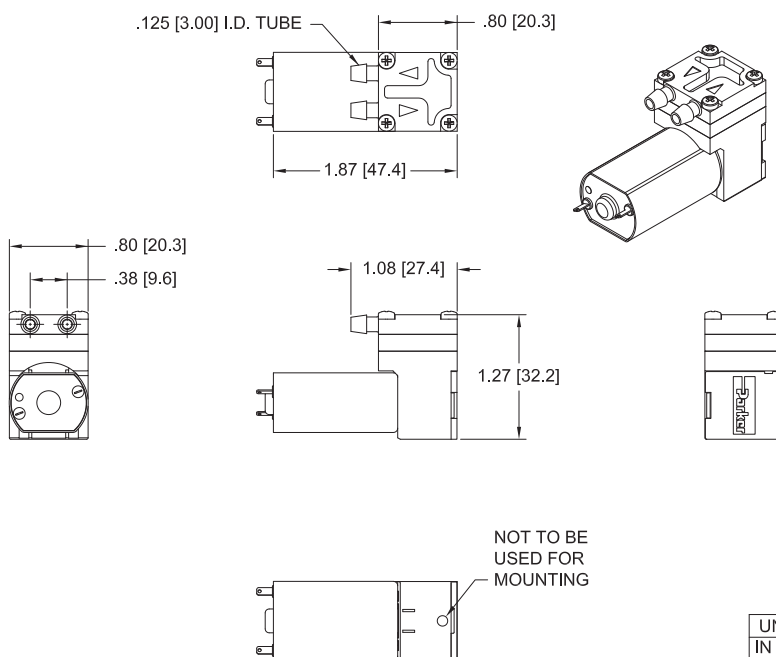

UNITS  
IN [MM]



Mechanical Integration

Dimensions

Coreless Brush Motor

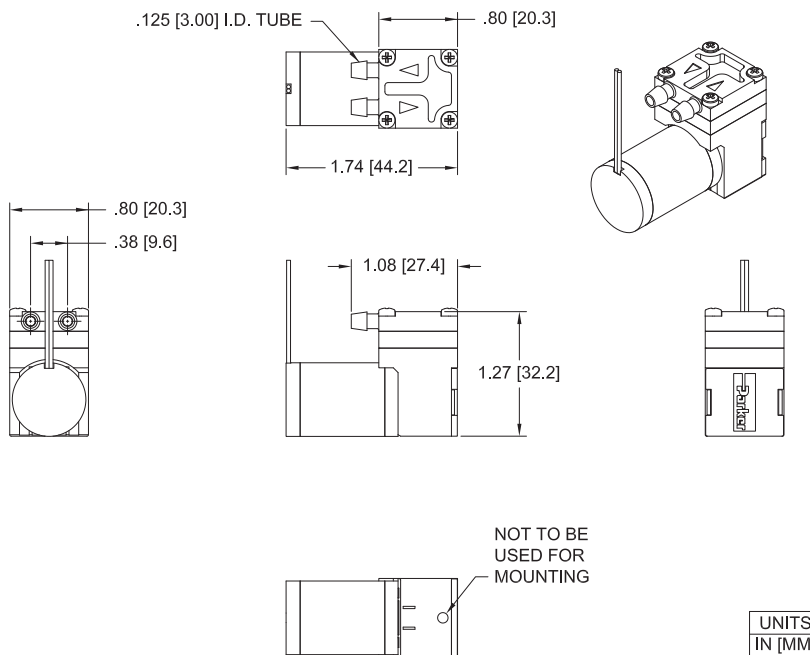

Brushless Slotless Motor

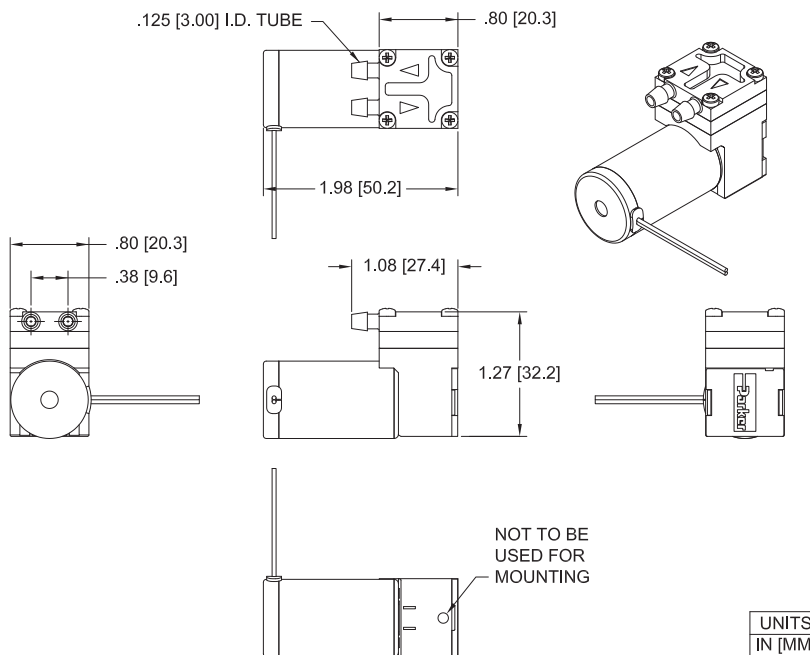

## CTS Series

## Micro Diaphragm Pumps (air/gas)

### Electrical Integration and Motor Control

#### PMDC Iron Core Brush Motor

Metal Terminals	Polarity of the terminals is marked on the motor with the red dot marking the positive terminal.
-----------------	--

#### Coreless Brush Motor

2 Wire	Red (+), Black (-)
Wire specification	24AWG, Insulation OD 0.038 in (0.97 mm), 20" (508 mm) Wire Leads

#### Brushless Slotless

2 Wire	Red (+), Black (-)
Wire specification	24AWG, Insulation OD 0.042 in (1.07 mm), 20" (508 mm) Wire Leads

#### Key Things to Remember

The pump is not a pressure holding device. An external check valve is recommended, if there is a pressure holding requirement.

Onboard PWM control is not provided with this pump.

Pump orientation does not affect performance or life.

### Typical Flow Diagram

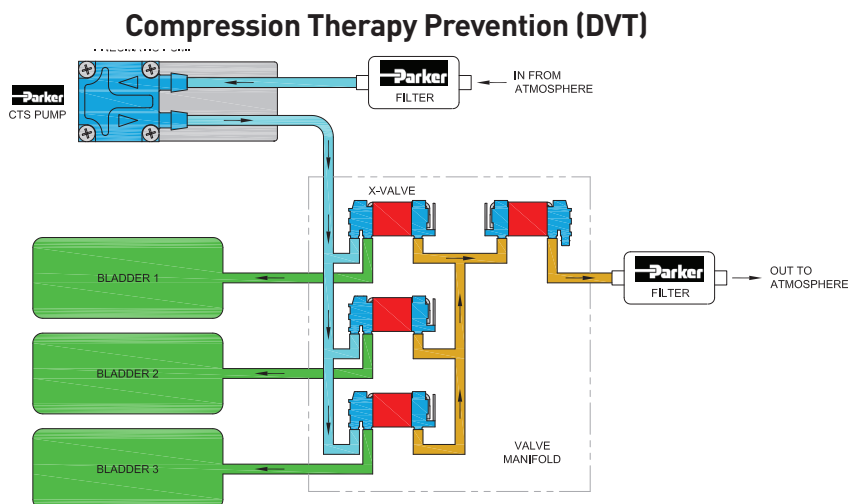

#### Pick-up Head

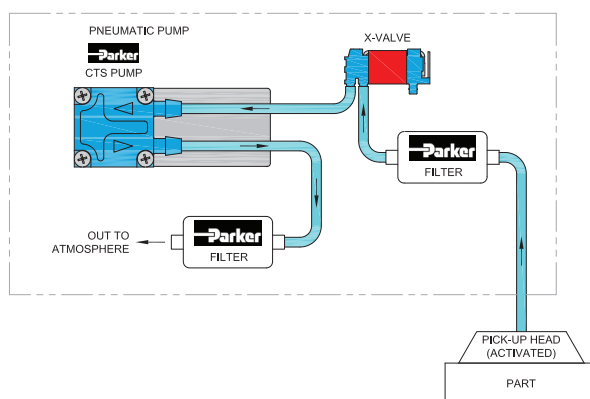

## Typical Flow Diagram

### Negative Pressure Wound Therapy (NPWT)

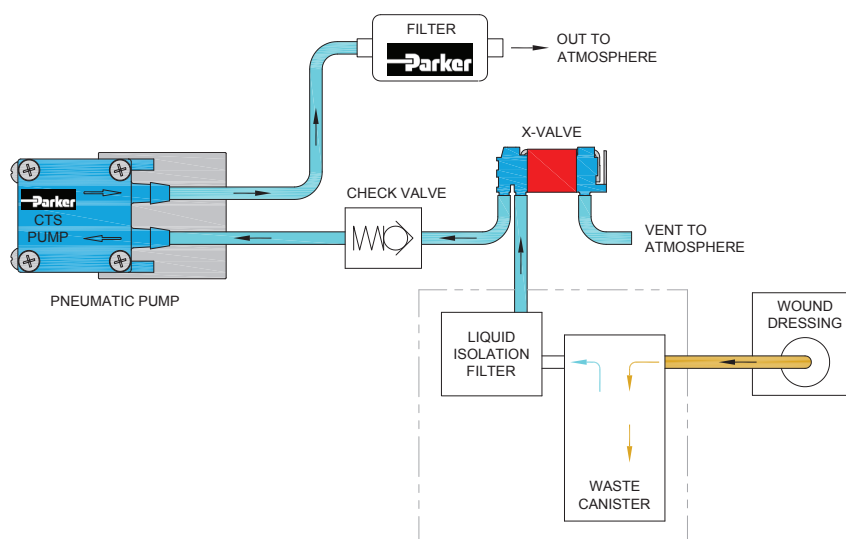

### Breast Pump

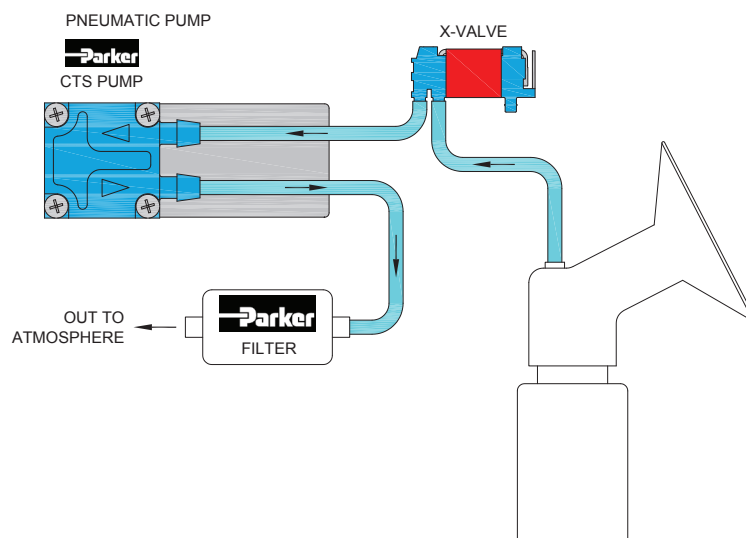

## CTS Series

## Micro Diaphragm Pumps (air/gas)

### Accessory Information

A **Filter-Muffler** is always recommended in the air inlet or outlet to reduce noise and risk of debris that may affect pump performance. See *Typical Flow Diagrams* for installation guidelines and Note 2 in Appendix at the end on noise

Typically a 40 micron filter is recommended to be supplied by the customer. Following are three other options of filtering specifications

**Part Number: 00492-15 (Filters to 10 microns)**

Dimensions: .78 [19.8], .125 [3.00] I.D. TUBE, .20 [5.0], 2.39 [60.7]

**Part Number: 00085-15**

Dimensions: .33 [8.4], 1.74 [44.2], .33 [8.4], Ø1.10 [27.9], Ø.12 [3.0], Ø.25 [6.4]

PORTS DESIGNED TO ACCEPT 1/8" I.D. SILICONE TUBE OR 3/16" I.D. POLYURETHANE TUBE

**Part Number: 1504-10**

Dimensions: Ø.300 [7.62] O.D. OF MUFFLER, "L", Ø.250 [6.35] O.D. OF TUBE, .170 [4.32]

UNITS IN [MM]

PART NUMBER	TUBING DUROMETER	TUBING LENGTH "L"
01504-10-0001	50	.500 [12.70]
01504-10-0002	70	.500 [12.70]
01504-10-0003	70	.650 [16.51]

### Chemical Compatibility Chart\*

Chemical	Chemical Compatibility of Wetted Path Materials			
	FKM	EPDM	AEPDM	PSU
Air	1	1	1	1
Ozone (1000 ppm)	4	4	4	1
Oxygen	1	1	1	1
Ethylene (Ethene)	1	4	1	1
Acetylene	1	1	1	1
Propane	1	4	4	1
Methane	1	4	4	1
Nitrogen	1	1	1	1
Carbon Dioxide	1	2	2	1
Halothane (Up to 5%)	1	4	4	-

#### Compatibility Legend

- EXCELLENT**  
Minimal or no effect
- GOOD**  
Possible swelling and/or loss of physical properties
- DOUBTFUL**  
Moderate or severe swelling and loss of physical properties
- NOT RECOMMENDED**  
Severe effect and should not be considered

*Note: Consult factory for other gases.*

\*The above is an Abbreviated Chemical Compatibility Chart. Please consult factory for details.



## Micro Diaphragm Pumps (air/gas)

## CTS Series

## Ordering Information

## CTS Single Head Pumps - General Purpose

Part No.	Vacuum: LPM @ Load						Free Flow	Pressure: LPM @ Load						Max		Motor Type	VDC	PCD* mA	Wetted Materials Diaphragm Valves-Gasket	
	24 in Hg	20 in Hg	16 in Hg	12 in Hg	8 in Hg	4 in Hg		4 psig	8 psig	12 psig	16 psig	20 psig	24 psig	28 psig	Vac in Hg					Press psig
	588 mm Hg	508 mm Hg	406 mm Hg	305 mm Hg	203 mm Hg	102 mm Hg		0	276 mbar	552 mbar	827 mbar	1103 mbar	1379 mbar	1655 mbar	1931 mbar					
E107A-12-090		0.2	0.5	0.9	1.3	1.9	2.6								22.5		Brush PMDC	9	295	EPDM, EPDM
E107-12-090		0.2	0.5	0.9	1.3	1.9	2.6								22.5		Brush PMDC	9	295	EPDM, EPDM
E129-13-120							2.6	1.8	1.4	1.0	0.8	0.5			21.5		Brush PMDC	12	345	AEPDM, EPDM
E107-13-090							2.5	1.7	1.4	0.9	0.6	0.3			23.5		Brush PMDC	9	345	AEPDM, EPDM
E222-13							2.5	1.8	1.4	1.1	0.9	0.7	0.5		12.0		Brush PMDC	9	395	AEPDM, EPDM
E177A-12		0.1	0.5	0.8	1.2	1.7	2.3								22.5		Brush PMDC	12	410	EPDM, EPDM
E138-13							2.1	1.6	1.3	1.0	0.7	0.5	0.3		28.0		Brush PMDC	12	410	AEPDM, EPDM
E189-12		0.2	0.6	0.9	1.2	1.5	2.1								22.5		Brush PMDC	6	450	EPDM, EPDM
E129-12-090		0.1	0.4	0.6	1.0	1.4	2.0								22.0		Brush PMDC	9	250	EPDM, EPDM
E129-13-090							2.0	1.3	1.0	0.7	0.5	0.4	0.2		30.0		Brush PMDC	9	330	AEPDM, EPDM
E163-11-120				0.2	0.8	1.2	2.0	1.1	0.6	0.3					16.0	14.5	Brush PMDC	12	180	AEPDM, EPDM
E107-12-060			0.2	0.4	0.7	1.0	1.8								20.5		Brush PMDC	6	265	EPDM, EPDM
E249-13							1.8	1.4	1.0	0.8	0.6				10.0		BLDC Slotless	9	250	EPDM, EPDM
E257-11					0.8	1.2	1.8	1.1	0.7						15.5	14.0	BLDC Slotless	12	175	AEPDM, EPDM
E134-11-120				0.2	0.6	0.9	1.7	0.9	0.4	0.3					14.0	14.0	Coreless Brush	12	100	AEPDM, EPDM
E155-11-120				0.3	0.6	1.1	1.7	1.2	0.8	0.2					15.0	15.0	Brush PMDC	12	180	EPDM, EPDM
E162-11-090				0.3	0.7	1.1	1.6	1.0	0.6	0.3					15.5	15.0	Brush PMDC	9	200	AEPDM, EPDM
E165-11-090				0.3	0.7	1.1	1.6	1.1	0.7	0.4					15.5	13.5	Coreless Brush	9	140	AEPDM, EPDM
E163-11-090				0.2	0.5	0.8	1.5	0.8	0.5	0.2					15.5	15.0	Brush PMDC	9	165	AEPDM, EPDM
E164-11-060			0.1	0.3	0.6	1.0	1.5	1.0	0.6	0.3	0.1				17.0	17.5	Coreless Brush	6	200	AEPDM, EPDM
E206-11				0.1	0.4	0.9	1.5	1.0	0.5	0.2					14.0	13.0	Brush PMDC	24	110	AEPDM, EPDM
E232-13							1.5	1.1	0.8	0.5	0.4				12.0		Brush PMDC	5	550	AEPDM, AEPDM
E107-13-060		0.1	0.3	0.5	0.7	1.1	1.5								23.5		Brush PMDC	6	320	EPDM, AEPDM
E155-11-090				0.2	0.5	0.8	1.3	0.8	0.4	0.2					15.0	15.0	Brush PMDC	9	170	EPDM, EPDM
E240-13							1.3	1.0	0.8	0.2					10.0		BLDC Slotless	9	350	EPDM, EPDM
E242-12			0.3	0.5	0.7	1.0	1.3								22.0		BLDC Slotless	6	300	AEPDM, EPDM
E164-11-050			0.1	0.3	0.5	0.8	1.2	0.8	0.5	0.3	0.1				17.5	17.0	Coreless Brush	5	215	AEPDM, EPDM
E129-12-060			0.1	0.3	0.5	0.8	1.2								20.0		Brush PMDC	6	275	EPDM, EPDM
E134-11-090				0.1	0.4	0.6	1.2	0.6	0.3	0.2					14.0	14.0	Coreless Brush	9	70	AEPDM, EPDM
E244-11				0.3	0.5	0.9	1.4	0.9	0.6	0.2					16.0	16.0	BLDC Slotless	9	180	AEPDM, EPDM
E230-13							1.2	0.7	0.5	0.3					12.0		Brush PMDC	5	320	AEPDM, EPDM
E248-13							1.1	0.9	0.6	0.5	0.3				10.0		BLDC Slotless	6	320	EPDM, EPDM
E161-11-050				0.2	0.4	0.8	1.1	0.8	0.4	0.2					16.5	16.5	Brush PMDC	5	300	AEPDM, EPDM
E165-11-060				0.2	0.4	0.7	1.1	0.7	0.4	0.2					13.5	13.5	Coreless Brush	6	135	AEPDM, EPDM
E162-11-060				0.2	0.4	0.7	1.0	0.6	0.4	0.2					16.0	16.0	Brush PMDC	6	190	AEPDM, EPDM
E258-11					0.3	0.7	1.0	0.7	0.2						11.0	9.5	BLDC Slotless	12	135	AEPDM, EPDM
E134-11-060				0.1	0.2	0.4	0.9	0.3	0.2	0.1					14.0	14.0	Coreless Brush	6	80	AEPDM, EPDM
E193-11-120					0.3	0.5	0.9	0.5	0.1						12.5	10.0	Brush PMDC	12	110	AEPDM, EPDM
E155-11-060				0.1	0.3	0.5	0.7	0.4	0.2	0.1					15.0	15.0	Brush PMDC	6	160	EPDM, EPDM
E243-11				0.2	0.3	0.6	0.7	0.5	0.3	0.2					16.0	14.5	BLDC Slotless	6	175	AEPDM, EPDM
E134-11-050				0.1	0.2	0.4	0.5	0.3	0.2						15.5	15.5	Coreless Brush	5	90	AEPDM, EPDM

Note: The Ordering Information Section includes a few selected part numbers for the product line. Other performances and configurations are available. Please contact your Sales Representative or an Application Engineer to discuss your application needs.

\*PCD: Peak Current Draw





## CTS Series

## Micro Diaphragm Pumps (air/gas)

### Accessory Ordering Information

Part No.	Filtering Level (Micron)	Filter Area	Operating Limitations:			Wetted Materials
00492-15	10	1.71 in sq (11 sq cm)	Max Temperature 80° C	Min Temperature 32° C	Max Pressure 65 PSI	Polypropylene
01504-10	75-90	.02 in sq (16 sq mm)	80° C	32° C	65 PSI	Polyethylene
00085-15	0.01	.39 in sq (252 sq mm)	110° C	32° C	125PSI	Nylon
Filter-Mufflers: To assist with filtration and optimize noise reduction. Tubing: Recommendation 1/8" ID						

Please click on the Order On-line button below (or go to [www.parker.com/precisionfluidics/cts](http://www.parker.com/precisionfluidics/cts)) to configure the CTS Miniature Diaphragm Pump for your application.

Serviceable – PPF products are designed for use through the rated life and Parker does not sell replacement parts, nor is it recommended to service these in the field

Note: In addition to Parker's innovative and flexible pump designs, we offer applications engineering expertise to our customers in order to configure and recommend the optimal pump for the application. Contact Parker Applications Engineering to discuss and configure alternate pump configurations to meet your specific application requirements. Providing information on the following requirements will assist us in developing an optimal solution for your application:

- Noise
- Operating Pressure / Vacuum
- Power Consumption
- Life Requirement
- Function in the Application
- Size
- Motor Control
- Media
- Voltage



## Appendix A

All performance data is typical based on standard conditions: 70°F and 14.7 psia (21°C and 1 bar).

1. Duty Dependent. For operation above 122°F (50°C) consult factory
2. Noise is dependent on the configuration and operation of the pump in the application. Parker has the ability to tailor the pump configuration when noise is a critical criterion in the effort to meet the performance requirements of the application. Noise level is tested to Parker protocol P-105.
3. Life rating can vary depending on application and operating conditions.
4. Custom motor options available. Custom motors may require a significant application potential. The standard motors can be configured with a special winding to meet a particular operation point at a specified voltage
5. Current range is dependent on motor type, voltage, pressure/vacuum and flow requirement. Lower levels possible depending on application.
6. Pump efficiency is a measure of the flow rate generated per unit of power consumed. Efficiency may change dependent on application and operating condition at free flow.

