

VPV Series Variable Displacement Vane Pumps

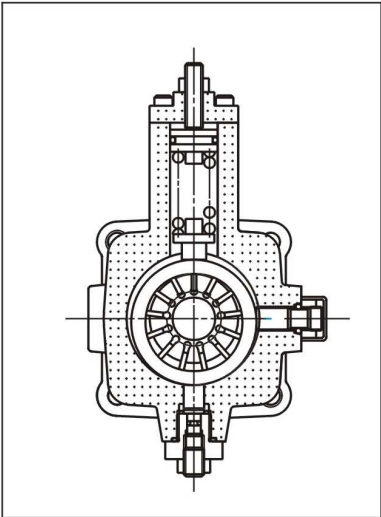
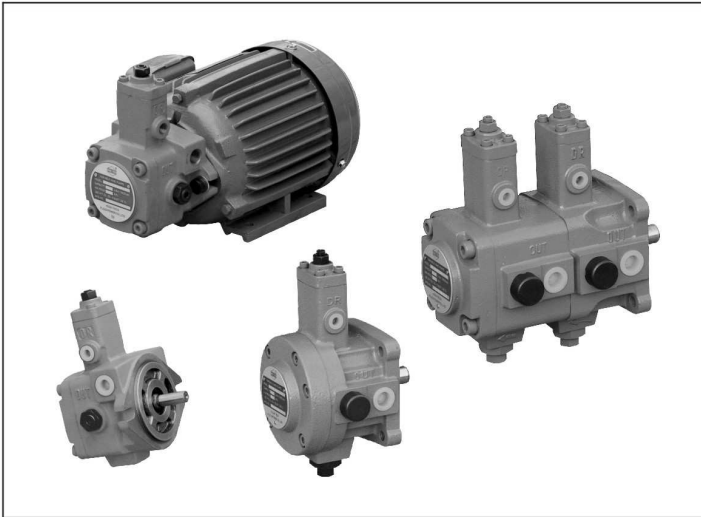

Single Pumps Model Code

M-	VPV1	-12	-55	-1.5	-10
Prefix, fluid compatibility	Series	outlet flow(L/min)	operating pressure range(MPa)	Input power(kW)	Design
M: With motor Omit: Without motor	VPV1	8	2.0	0.75	-10
		12			
		15			
	VPV2	20	5.5	2.25	-20
		30	7.0	3.75	
		40			

Double Pumps Model Code

VPV22	-30	-70	/-30	-55	-20
Series	Outlet Flow L/min (shaft end pump)	Operating pressure range MPa (shaft end pump)	Outlet Flow L/min (cover end pump)	Operating pressure range MPa (cover end pump)	Design
VPV11	8	2.0	8	5.5	-20
	12		12		
	15		15		
	20		20		
VPV22	30	7.0	30	7.0	-20
	40		40		

Specifications

Model	Max. Displacement mL/r	Flow (0MPa 1800r/min) L/min	Operating pressure range MPa	Speed range r/min	Rotation (viewed from shaft end)	Input power kW(HP)	
						1800r/min	1500r/min
VPV1-8-20	5.3	9.5	0.8-2.0	800-1800	Right hand (for clockwise)	0.29(0.5)	0.29(0.5)
VPV1-8-35			1.5-3.5			0.59(1)	0.44(0.5)
VPV1-8-55			3.0-5.5			0.87(1)	0.59(1)
VPV1-8-70			5.0-7.0			1.19(1.5)	1.19(1.5)
VPV1-12-20	6.7	12	0.8-2.0			0.37(0.5)	0.37(0.5)
VPV1-12-35			1.5-3.5			0.75(1)	0.55(1)
VPV1-12-55			3.0-5.5			1.1(1.5)	0.75(1.0)
VPV1-12-70			5.0-7.0			1.5(2)	1.5(2.0)
VPV1-15-20	8.3	15	0.8-2.0			0.5(1)	0.55(1)
VPV1-15-35			1.5-3.5			1.1(1.5)	0.75(1.0)
VPV1-15-55			3.0-5.5			1.5(2)	1.1(2)
VPV1-15-70			5.0-7.0			1.5(2)	1.5(2)
VPV1-20-20	11.1	20	0.8-2.0			0.75(1)	0.55(1)
VPV1-20-35			1.5-3.5			1.1(2)	1.1(2)
VPV1-20-55			3.0-5.5			1.5(2)	1.5(2)
VPV1-20-70			5.0-7.0			2.2(3)	2.2(3)
VPV2-30-20	16.7	30	0.8-2.0	1.1(2)	0.75(1)		
VPV2-30-35			1.5-3.5	1.5(2)	1.5(2)		
VPV2-30-55			3.0-5.5	2.2(3)	2.2(3)		
VPV2-30-70			5.0-7.0	3.75(5)	3.0(5)		
VPV2-40-20	22.2	40	0.8-2.0	1.5(2)	1.1(2)		
VPV2-40-35			1.5-3.5	2.2(3)	2.0(3)		
VPV2-40-55			3.0-5.5	3.75(5)	3.0(5)		
VPV2-40-70			5.0-7.0	5.5(7.5)	4.0(5)		

Installation dimensions

VPV1-**-**-10

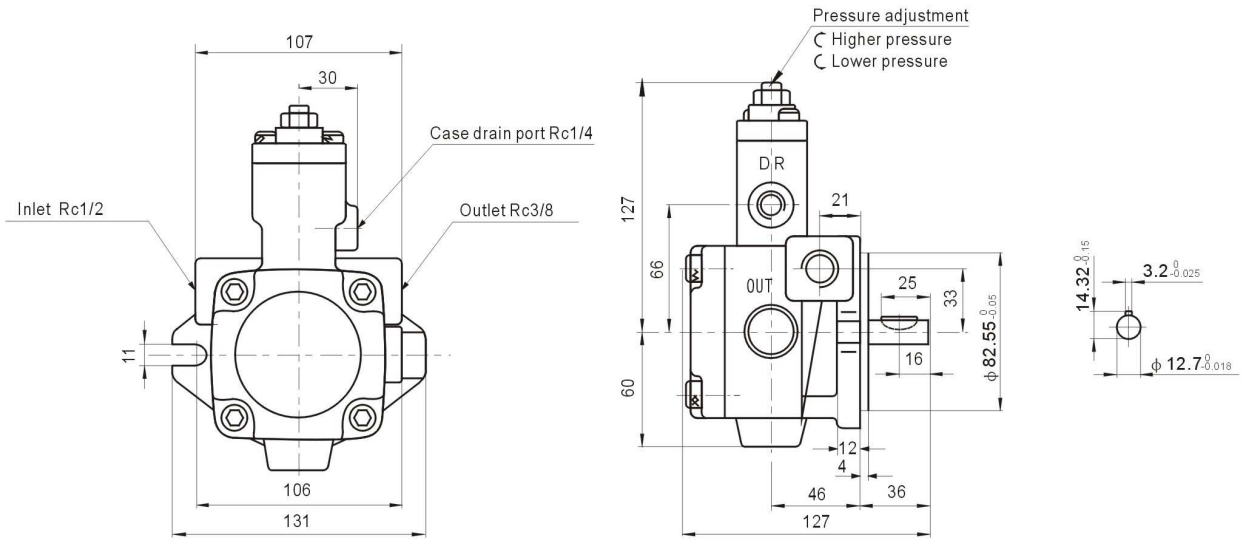

Note: No flow adjustment

VPV2-**-**-20

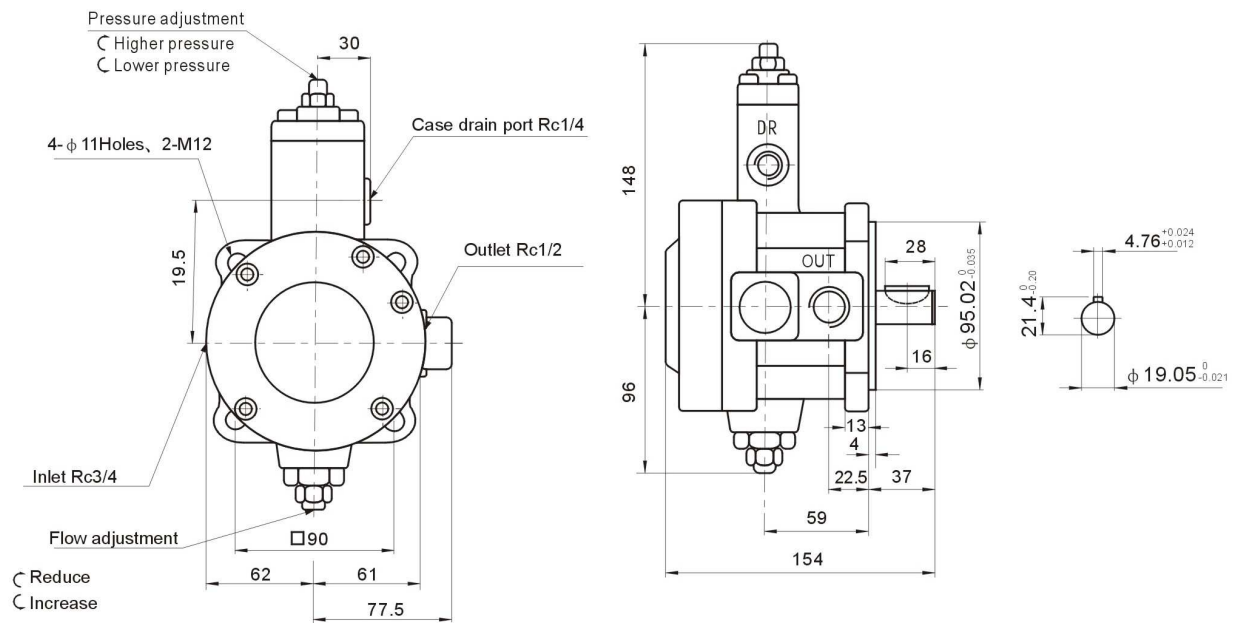

Installation dimensions

M-VPV1-※

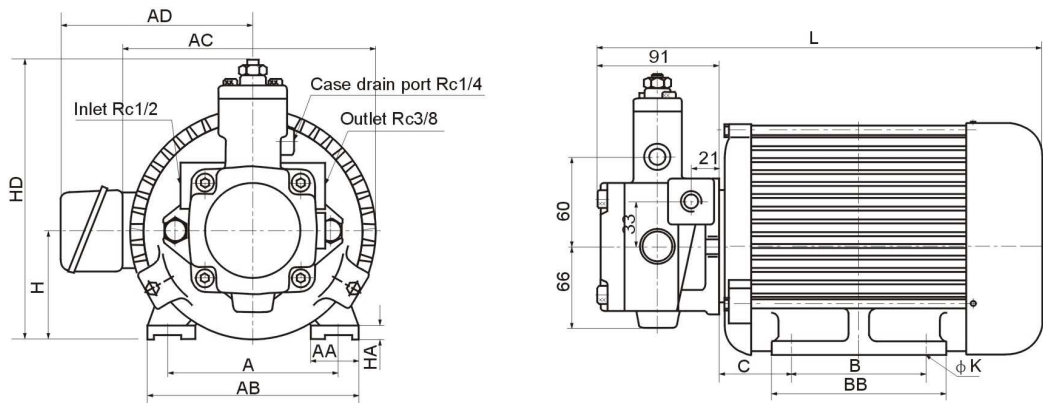

Outlet flow L/min	Pressure MPa	Input power KW	A	AA	AB	AC	AD	B	BB	C	H	HA	HD	K	L
12	3.5	0.75	125	35	155	177	140	100	130	53.5	80	10	207	10	331
	5.5	0.75	125	35	155	177	140	100	130	53.5	80	10	207	10	331
	7.0	1.50	140	35	170	196	160	125	150	57	90	10	227	10	369
15	3.5	0.75	125	35	155	177	140	100	130	53.5	80	10	207	10	331
	5.5	1.50	140	35	170	196	160	125	150	57	90	10	227	10	369
	7.0	1.50	140	35	170	196	160	125	150	57	90	10	227	10	369
20	3.5	0.75	125	35	155	177	140	100	130	53.5	80	10	207	10	331
	5.5	1.50	140	35	170	196	160	125	150	57	90	10	227	10	369
	7.0	1.50	140	35	170	196	160	125	150	57	90	10	227	10	369

M-VPV2-※

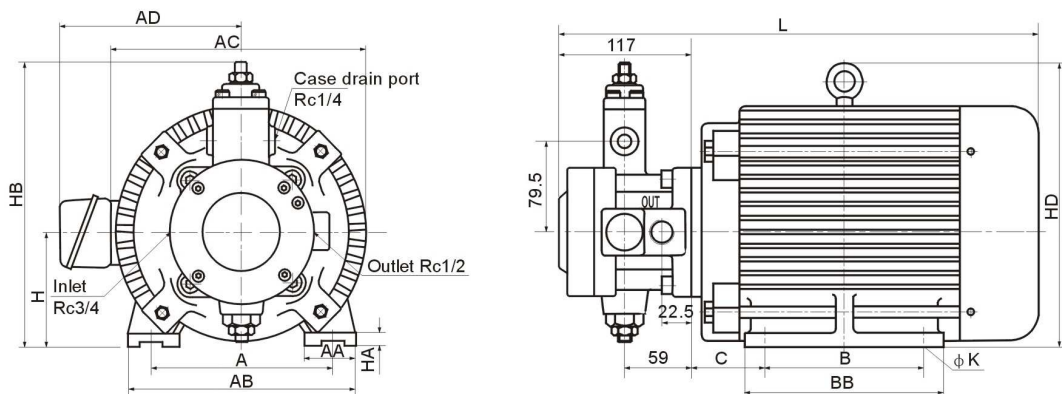

Outlet flow L/min	Pressure MPa	Input power KW	A	AA	AB	AC	AD	B	BB	C	H	HA	HB	HD	K	L
30	3.5	1.5	140	35	170	196	160	125	150	57	90	10	238	-	12	395
	5.5	2.25	160	45	200	225	160	140	175	65	100	12	248	247	12	424
	7.0	3.75	190	45	228	245	180	140	175	73.5	112	12	260	265	12	447
40	3.5	1.5	140	35	170	196	160	125	150	57	90	10	238	-	12	395
	5.5	3.75	190	45	228	245	180	140	175	73.5	112	12	260	265	12	447
	7.0	5.5	216	45	250	270	190	140	175	77	132	16	280	310	12	452

Installation dimensions

VPV11

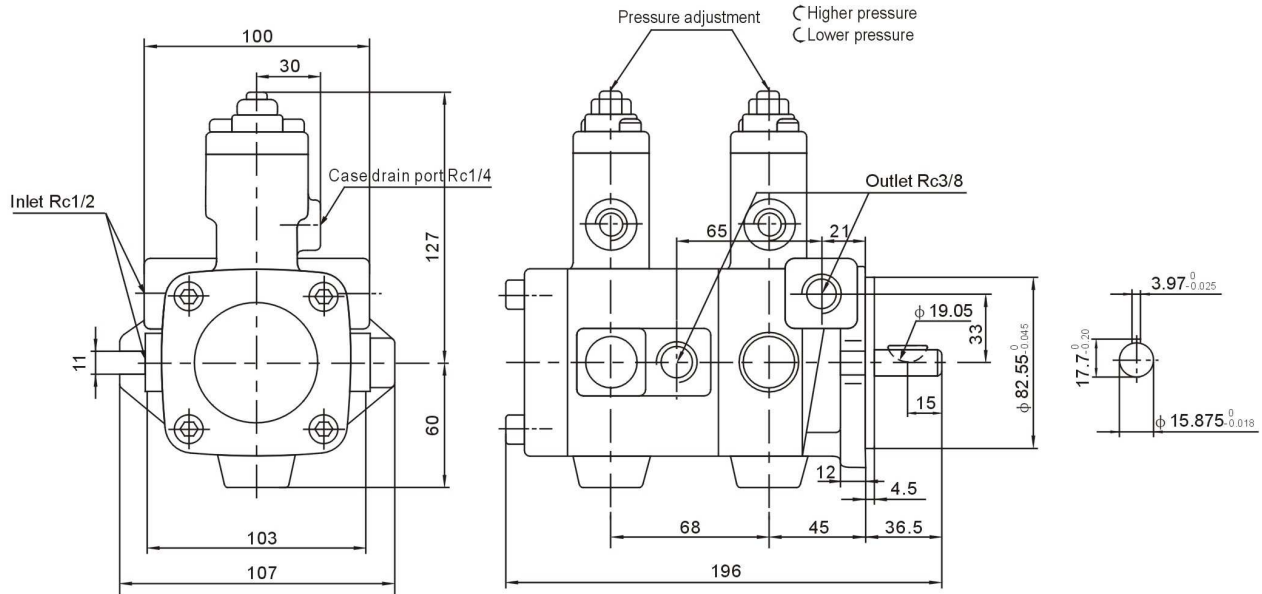

Note: No flow adjustment

VPV22

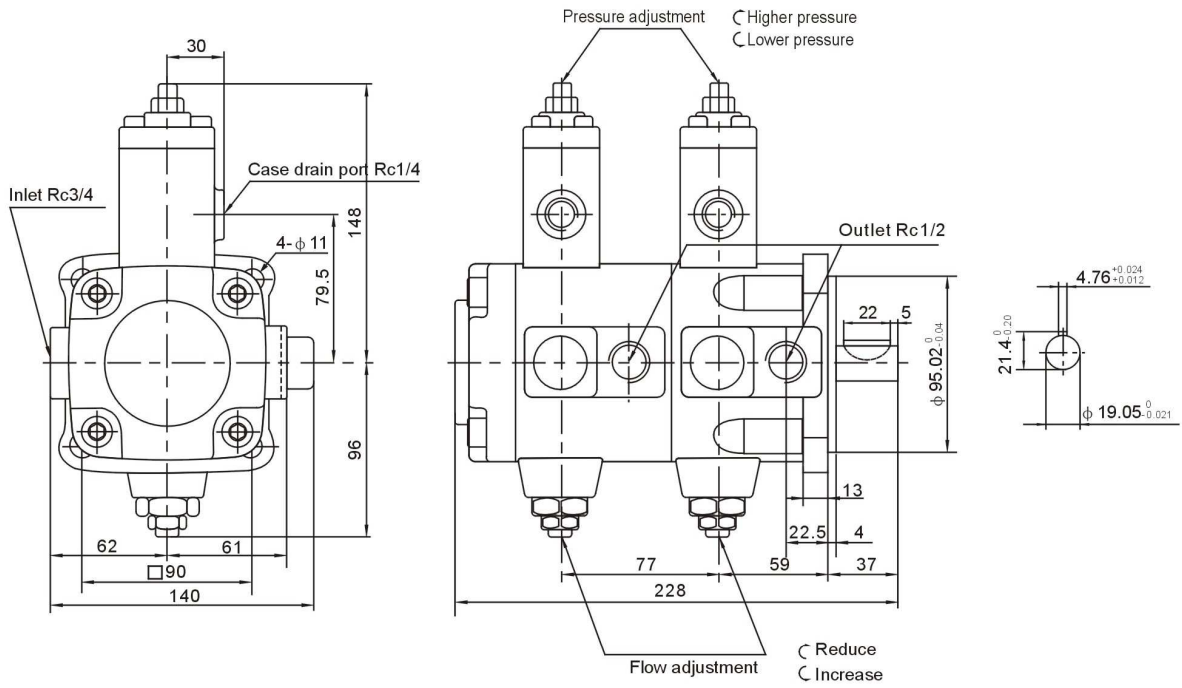

Characteristic Curves

VPV1-12-35

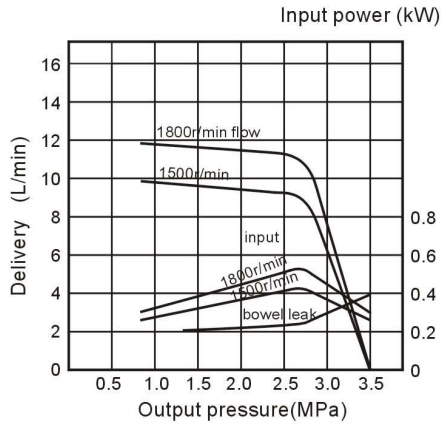

VPV1-15-35

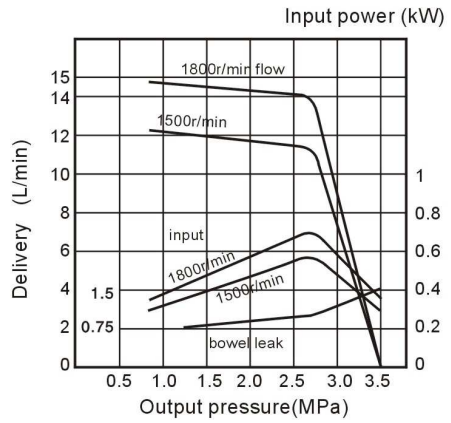

VPV1-12-55

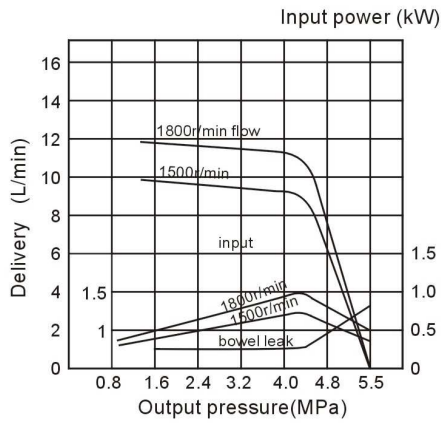

VPV1-15-55

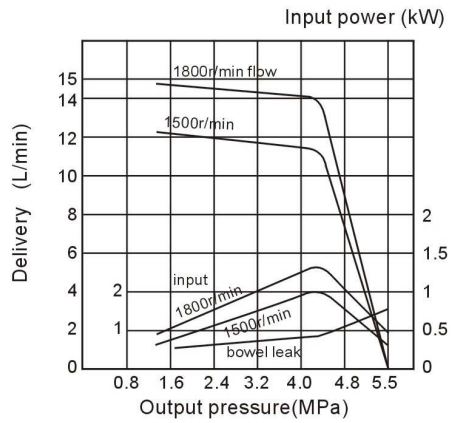

VPV1-12-70

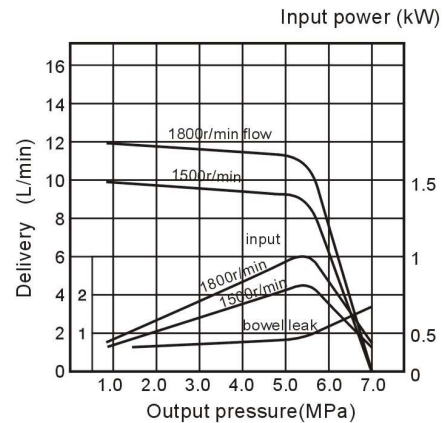

VPV1-15-70

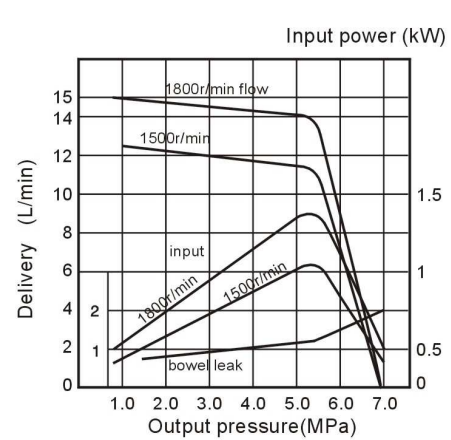

Installation dimensions

VPV1-20-35

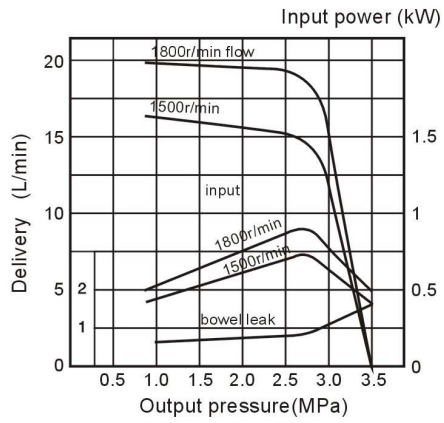

VPV2-30-35

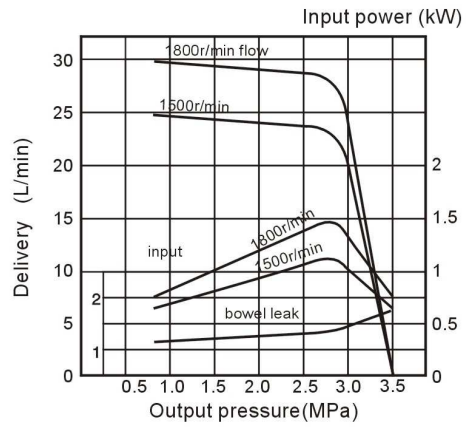

VPV1-20-55

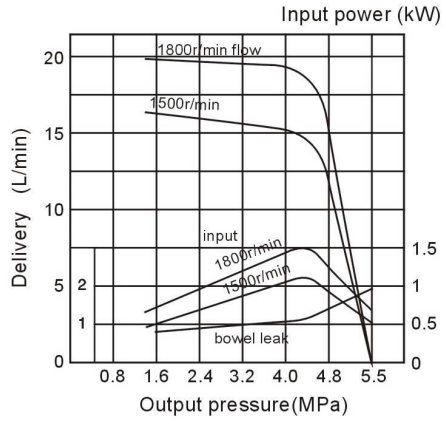

VPV2-30-55

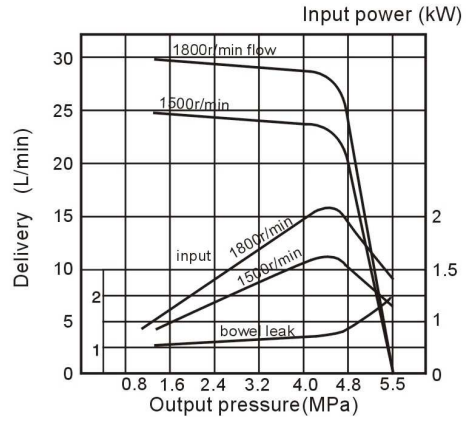

VPV1-20-70

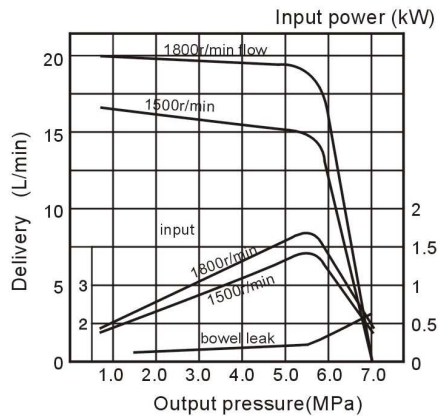

VPV2-30-70

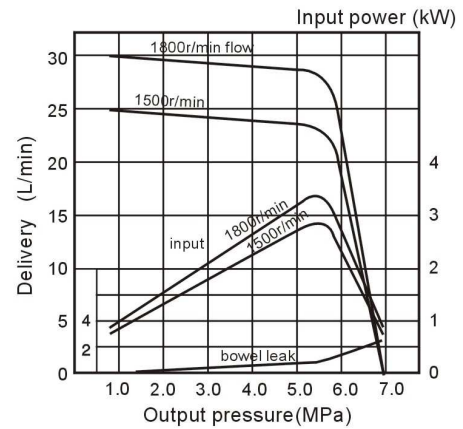

Characteristic Curves

VPV2-40-35

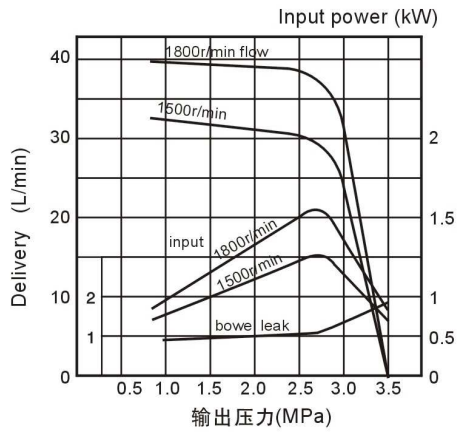

VPV2-40-55

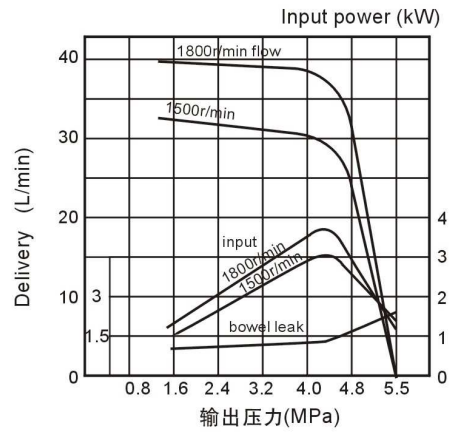

VPV2-40-70

